

WHEELED EXCAVATOR



Specifications

Operating weight	8400 kg
Engine power	67 kW (91 HP)
Bucket capacity	87-348 l
Dig depth	4.08 m
Reach	7.58 m

Features

- ▶ Short-tail machine
- ▶ Extra-wide blade for dozer applications
- ▶ Boom systems: monobloc, TPA or circular boom
- ▶ Comfort cab with perfect all-round visibility
- ▶ Increased productivity thanks to load sensing hydraulics
- ▶ Knickmatik® allows for working closely alongside walls
- ▶ Wide range of proven working tools

WORKS FOR YOU.™

SPECIFICATIONS

ENGINE

Manufacturer, model	Deutz, TCD 2012 L04
Type	4-cylinder diesel engine, Tier 3
Combustion	4-stroke cycle, direct fuel injection
Displacement	4040 cm ³
Net power rating at 2000 rpm (ISO 9249)	67 kW (91 hp)
Torque	360 Nm at 1600 rpm
Cooling system	Water

ELECTRICAL SYSTEM

Nominal voltage	12 V
Battery	12 V / 110 Ah / 850 A
Generator	12 V / 95 Ah
Starter	12 V / 3.1 kW

TRANSMISSION

Hydrostatic travel drive with automatic adjustment of drawbar pull and speed. 4-wheel drive from reduction gear on front axle via cardan shaft to rear axle. Infinitely variable speed control forward and reverse.

2 speed ranges:

"Low"	0-6 kph
"High"	0-20 kph

AXLES

Front: oscillating planetary drive axle, oscillating angle 11.5°.

Rear: rigid planetary drive axle.

TIRES

Standard	8.25-20, 12 PR twin tires
----------	---------------------------

BRAKES

Service brake: Hydraulic pump accumulator two-circuit brake, acting on oil-immersed multi-disc brakes of front and rear axle.

Excavator brake: Acting on front and rear axle due to lockable service brake.

Auxiliary brake: Hydrostatic travel drive in closed circuit acting as non-wearing auxiliary brake.

Parking brake: Hydraulic spring-loaded brake, electrically actuated

STEERING

Fully hydraulically controlled front axle with integrated steering cylinder.

Max. steering angle	32 °
---------------------	------

SWING SYSTEM

Hydrostatic drive with 2-stage planetary gear and axial piston fixed displacement motor, also acts as wear-resistant brake. In addition, automatically controlled spring-loaded multi-disc brake acting as parking brake.

Swing speed	0-10 rpm
-------------	----------

KNICKMATIK®

Lateral parallel adjustment of boom arrangement at full dig depth.

Angle of articulation / lateral adjustment left	53° / 870 mm
---	--------------

Angle of articulation / lateral adjustment right	67° / 990 mm
--	--------------

FÜLLMENGEN

Diesel-Tankinhalt	190 l
Hydrauliksystem (inklusive Tank)	190 l

FLUID CAPACITIES

Fuel tank	190 l
Hydraulic system (incl. tank)	190 l



OPERATING DATA, STANDARD EQUIPMENT

Operating weight (monobloc / TPA / circular boom) acc. to ISO 6016	8400 / 8600 / 8800 kg
Total length, travel position (monobloc / TPA / circular boom)	5380 / 5520 / 5370 mm
Total height (travel position)	3950 mm
Transport dimensions: Monobloc / TPA / circular boom (L x H)	6520x2930 / 6120x2930 / 6680x2930 mm
Total width (twin tires)	2450 mm
Total height (top of cab)	2930 mm
Tread width	1942 mm
Wheelbase	2240 mm
Ground clearance below cardan shaft	400 mm
Turning radius	6700 mm
Uppercarriage tailswing	1500 mm
Uppercarriage frontswing	2750 mm
Working envelope 180°	4460 mm
Working envelope 360° (monobloc / TPA / circular boom)	6090 / 5920 / 3330 mm
Bucket digging force acc. to ISO 6015	53,200 N
Stick digging force acc. to ISO 6015 (TPA boom)	42,600 N
Stick digging force acc. to ISO 6015 (circular boom)	42,000 N

HYDRAULIC SYSTEM

Travel hydraulics: Closed circuit, independent from working hydraulics.

Pump capacity, max.	112 l/min
Working pressure, max.	420 bar

Working hydraulics: Axial-piston variable displacement pump with load sensing, coupled with a load-independent flow distribution (LUDV). Simultaneous, independent control of all movements. Sensitive maneuvers irrespective of loads.

Pump capacity, max.	142 l/min
Working pressure, max.	280 bar

The thermostatically controlled oil circuit ensures that the oil temperature is promptly reached and avoids overheating. Return filter installed in oil tank allows for eco-friendly replacement of filter elements.

Dual gear pump for all positioning and swing movements. Pressure cut-off valve for sensitive and energy-saving swing movements.

Pump capacity, max.	40+26 l/min
Working pressure, max.	230 bar

Control circuit for work attachments, proportionally actuated:

Pump capacity, adjustable	20-100 l/min
Working pressure, max.	280 bar

Two servo-assisted joystick controls (ISO) for excavator operations.

CAB

Spacious, sound-insulated full-vision steel cab. Sliding window on right-hand side. Safety glass windows, thermo windows tinted in green. Skylight thermo window, bronze tinted. Panoramic rear window. Front window supported by pneumatic springs, lockable for ventilation and slidable under cab roof. Windshield washer system. Storage compartment. Preparation for radio installation. Left-hand outside rear-view mirror.

Cab heating with front window defroster by engine coolant heat exchanger with 3-stage fan. Choice between fresh air and recirculating air, fresh air filter.

Operator's seat MSG 85 (standard version), hydraulic damping, extra-high backrest, adjustable armrests, weight, longitudinal and tilt adjustments. Lap belt.

Instrument panel on the right-hand side of the operator's seat with visual & acoustic warning device, hour-meter and safety module.

Working floodlights Halogen H-3.

Sound level values in compliance with EC-directives.

WORKING RANGES & DIMENSIONS: TPA BOOM / CIRCULAR BOOM

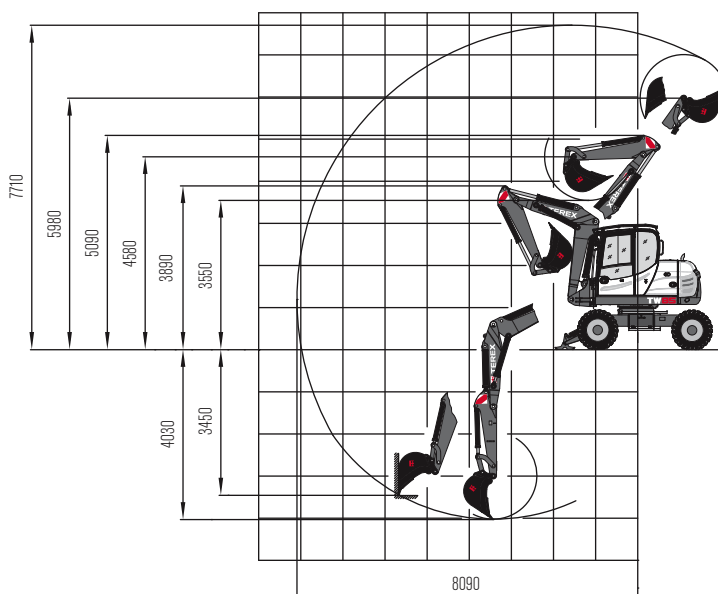
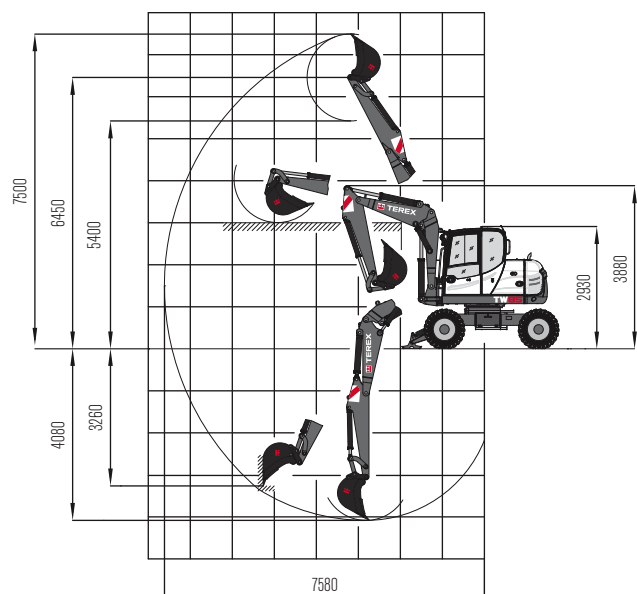

LIFTING CAPACITIES

Bucket hinge height		Load radius from center of ring gear							
		3.0 m		4.0 m		5.0 m		6.0 m	
TPA boom		End	Side	End	Side	End	Side	End	Side
3.0 m	A	-	-	2.39	1.99	1.67	1.44	1.54	1.00
	V	-	-	1.83	1.90	1.31	1.35	0.87	0.94
1.5 m	A	3.74	2.85	2.23	1.89	1.91	1.35	1.91	0.97
	V	2.59	2.72	1.67	1.79	1.17	1.26	0.84	0.90
0 m	A	4.34	2.80	2.61	1.73	1.98	1.26	1.59	0.95
	V	2.37	2.60	1.54	1.64	1.10	1.19	0.80	0.87
-1.0 m	A	4.54	2.63	2.81	1.71	2.14	1.22	1.42	0.90
	V	2.30	2.49	1.47	1.59	1.06	1.14	0.78	0.85

Bucket hinge height		Load radius from center of ring gear							
		3.0 m		4.0 m		5.0 m		6.0 m	
Circular boom		End	Side	End	Side	End	Side	End	Side
3.0 m	A	5.50	3.20	3.20	1.90	2.30	1.40	1.90	0.90
	V	2.90	3.10	1.60	1.80	1.20	1.30	0.80	0.90
1.5 m	A	5.10	2.90	3.80	1.80	2.60	1.30	1.90	0.90
	V	2.60	2.70	1.70	1.80	1.10	1.20	0.70	0.90
0 m	A	5.80	2.40	2.90	1.70	2.50	1.20	2.00	0.80
	V	2.10	2.30	1.50	1.60	0.90	1.10	0.70	0.80
-1.0 m	A	5.60	2.30	2.90	1.50	2.00	1.10	1.60	0.80
	V	2.00	2.20	1.30	1.50	1.00	1.10	0.70	0.80

All values in tons (t) were determined acc. to ISO 10567 and include a stability factor of 1.33 or 87% of the hydraulic lifting capacity. All values were determined with load hook. With bucket attached, the weight difference between bucket and load hook must be deducted from the permissible operating loads. When used for load hook applications, excavators must be equipped with hose-rupture valves and overload warning device in compliance with EN 474-5.

Working equipment: TPA boom, dipperstick 2000 mm / circular boom, dipperstick 1650 mm; twin tires.

Abbreviations: S = Supported by blade, T = Traveling

DIMENSIONS

Fig. 1: Transport position

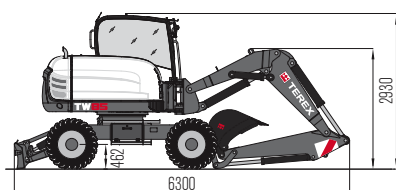

Fig. 2: Working envelope

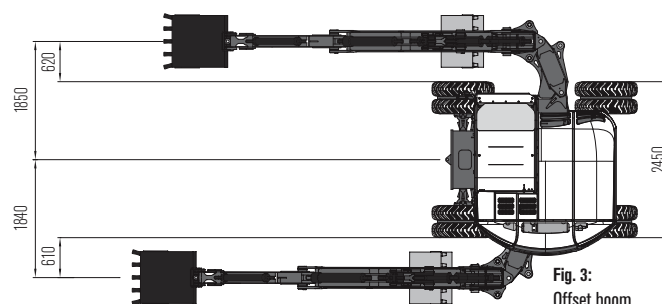
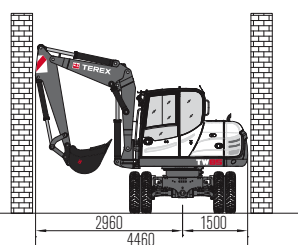

Fig. 3: Offset boom

WORK ATTACHMENTS

BUCKETS

Bucket, QAS, light material, without teeth	300 mm wide, capacity 87 l
Bucket, QAS, light material, without teeth	400 mm wide, capacity 127 l
Bucket, QAS, light material, without teeth	600 mm wide, capacity 212 l
Bucket, QAS	300 mm wide, capacity 87 l
Bucket, QAS	400 mm wide, capacity 127 l
Bucket, QAS	500 mm wide, capacity 169 l
Bucket, QAS	600 mm wide, capacity 212 l
Bucket, QAS	800 mm wide, capacity 303 l
Bucket, QAS	900 mm wide, capacity 348 l
Ditch-cleaning bucket, QAS	1250 mm wide, capacity 251 l
Ditch-cleaning bucket, QAS	1500 mm wide, capacity 305 l
Swing bucket, QAS	1500 mm wide, capacity 305 l

OPTIONAL EQUIPMENT

BOOM OPTIONS

Monobloc boom, with dipperstick 2000 mm
TPA boom, with dipperstick 2200 mm
Circular boom, with dipperstick 1650 mm
Monobloc boom, offset boom 850 mm, with dipperstick 2000 mm

TIRES

365/70 R 18 MPT E-70 Conti (single tires)
500/45-20 (single wide tires)

HYDRAULIC SYSTEM

Second control circuit (e.g. for sorting grab)	Biodegradable hydraulic oil / ester-based HLP 68 (Panolin)
Open return	Conversion kit from ISO controls to Schaeff controls
Hose-rupture / load-retaining valve for dipperstick (monobloc boom)	Hose-rupture / load-retaining valve for dipperstick and intermediate boom (TPA boom)
Hose-rupture / load-retaining valve for dipperstick and intermediate boom (circular boom)	Bucket control change-over (in case of forklift operation)
Hydraulic boom height limitation	

DRIVER'S STAND

Operator's seat MSG 95 (comfort version), air damping, extra-high backrest, longitudinal-horizontal suspension, seat and backrest heating

GRABS

Clamshell grab GM 2325, grab swing brake	set of shells 325 mm wide, capacity 150 l
Clamshell grab GM 2400, grab swing brake	set of shells 400 mm wide, capacity 200 l
Clamshell grab GM 2500, grab swing brake	set of shells 500 mm wide, capacity 250 l
Clamshell grab GM 2600, grab swing brake	set of shells 600 mm wide, capacity 260 l
Ejector	

OTHER WORK ATTACHMENTS

Ripper tooth / QAS (1 tooth)	Cutting unit
Hydraulic hammer	Quick-change adapter for hydraulic hammer
Auger	Bolt-on load hook for bucket rod
Load hook integrated in quick-attach system	Fork carrier, 1240 mm wide
Further work attachments available on request	Forks, 1120 mm long, 100 mm wide, 45 mm high

ENGINE

Automatic idling system	Diesel exhaust cleaner
-------------------------	------------------------

CAB

Lighting package: 1 double beam working floodlight - cab-mounted rear center, 1 working floodlight cab-mounted - front right	FOPS - skylight guard
Yellow beacon	Radio set installation kit

OPTIONAL SUPPORT/DOZER SYSTEMS

Rear support blade, 2460 mm wide (with twin and wide tires)
Rear support blade, 2290 mm wide (with single tires)
Outrigger plates, flat, oscillating
Outrigger plates, rubber-coated, oscillating
Front dozer blade, 2460 mm wide

OTHER OPTIONAL EQUIPMENT

Air conditioning	High-speed version, 25 kph
Quick-attach system, mechanical (genuine Lehnhoff system), type MS08	Engine-independent diesel heater with fresh air circulation and timer
Anti-theft device (immobilizer)	Travel drive shut-off in case of hand-throttle actuation
Additional tool box	Electrical refueling pump
Automatic idling system	Special coating / adhesive films
Additional rear weight	Further optional equipment available on request

www.terexconstruction.com

Effective Date: February 2011. Product specifications and prices are subject to change without notice or obligation. The photographs and/or drawings in this document are for illustrative purposes only. Refer to the appropriate Operator's Manual for instructions on the proper use of this equipment. Failure to follow the appropriate Operator's Manual when using our equipment or to otherwise act irresponsibly may result in serious injury or death. The only warranty applicable to our equipment is the standard written warranty applicable to the particular product. Terex makes no other warranty, express or implied. Products and services listed may be trademarks, service marks or trade-names of Terex Corporation and/or its subsidiaries in the USA and other countries. All rights are reserved. "Terex" is a registered trademark of Terex Corporation in the USA and many other countries.
Copyright © 2012 Terex Corporation (R4_091212)

Ref. no.: TEREX578UK

Terex Deutschland GmbH
Geschäftsbereich Compact
Kraftwerkstr. 4, D-74564 Crailsheim
Tel: +49 (0)7951 / 9357-0 Fax: +49 (0)7951 / 9357-671
construction@terex.com www.terex.com



WORKS FOR YOU.™